

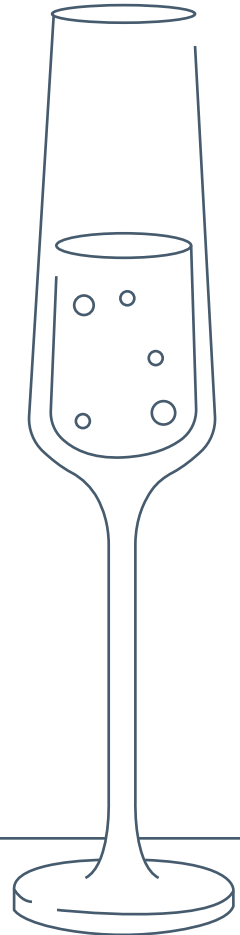

WEDGEWOOD
HOTEL & SPA

BACCHUS
LOUNGE &
COCKTAIL
MENU



COCKTAILS

WINE

SPIRITS

FOOD

COCKTAILS

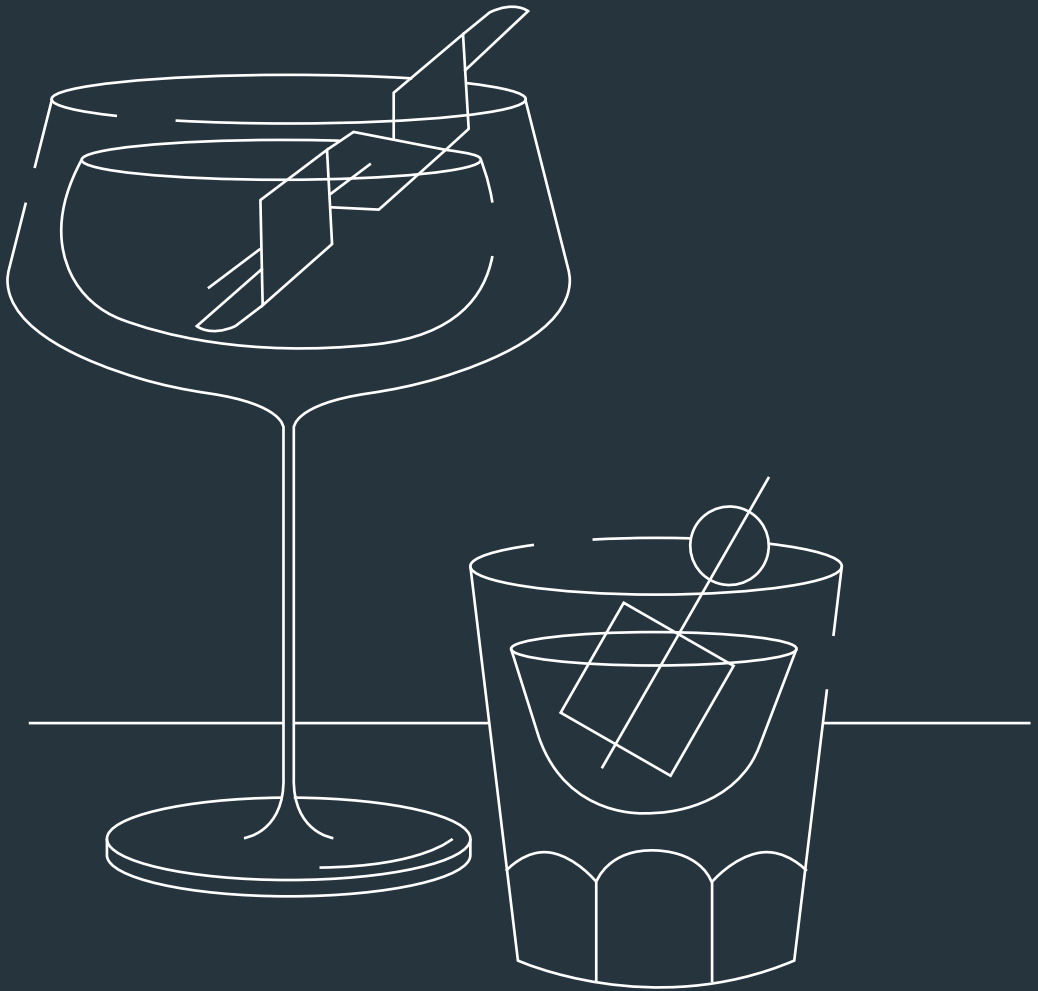

Summer Cocktails

Daybreak | 28

A crisp botanical lift, featuring cucumber, lime, and soft florals with a delicate finish
1.5 oz Hendrick's Gin, 0.5 oz Elderflower Liqueur, Cucumber Water,
Basil-Mint Syrup, Fresh Lime Juice

Island's Light | 22

All the familiar flavours of a Piña Colada, elevated with bright, elegant elements
1.5 oz Dark Rum, 0.5 oz Spiced Rum, Cream of Coconut, Pineapple Juice,
Fresh Lime Juice

The Pink Hour | 24

Playful yet poised, balancing a subtle sweetness of watermelon with a critic tanginess
1.5 oz Blanco Tequila, 0.5 oz Campari, Watermelon Syrup, Fresh Lime Juice,
Egg Whites

Sundown | 22

Refreshing strawberry and banana lifted by citrus, with subtle vanilla and a smooth, mellow finish
1.25 oz Dark Rum, 0.5 oz Banana Liqueur, 0.25 oz Vanilla
Liqueur, Fresh Lemon Juice, Coconut Syrup, Strawberry

Evening Harvest | 28

*Lush dark berries and bright citrus layered with aromatic thyme
and a refined sparkling finish*
1.5 oz Reposado Tequila, 0.5 oz Crème de Cassis, Fresh
Lime Juice, Thyme Syrup, Lambrusco



Mocktails

SGT Pepper | 14

Pineapple, Lemon, Simple Syrup, Tonic, Cucumber, Pepper

Ginger Lotus | 12

Ginger Beer, Orange Juice, Lemon

No-groni | 14

Bitter, sweet, herbal complexity with citrus notes

NOA Non-Alcoholic Vermouth, Italian Aperitif, and Gin, Muddled Orange Peel

Espresso Mocktini | 15

Coffee-forward, smooth, gently sweet

NOA Non-Alcoholic Coffee Liqueur, NOA Amaretto, Fresh Espresso, Simple Syrup

Hai Tea Mojito or Hibiscus | 11

355ml Can



2 oz CLASSICS

Moscow Mule | 19

Ketel One Vodka, Lime Juice, Ginger Beer, Lime

Clover Club | 21

Tanqueray Gin, Chambord, Lemon Juice, Sugar, Egg White

Dark N' Stormy | 19

Goslings Rum, Lime Juice, Ginger Beer, Angostura Bitters, Mint

Sazerac | 20

Canadian Club, Angostura Bitter, Peychaud's, Sugar

Corpse Reviver No. 2 | 19

Tanqueray Gin, Lillet, Cointreau, Lemon Juice, Pernod

Hemingway Daquiri | 18

Bacardi White Rum, Maraschino liqueur, Lime Juice, Grapefruit Juice, Sugar

2oz MODERN CLASSICS

Revolver | 21

Bourbon, Tia Maria, Orange Bitters, Orange Peel

Old Cuban | 20

8 Year Bacardi, Lime Juice, Sugar, Angostura Bitters, Sparkling Wine

Dalmatian | 20

Luksusowa Vodka, Sugar, Grapefruit Juice, Cracked Black Pepper

Honey Bee | 26

1.5oz Casamigos Reposado, St Germain Honey, 0.75oz Prosecco, Honey Comb

Gin Basil Smash | 18

Tanqueray Gin, lemon Juice, Sugar, Basil



WINE



WINE	6oz	½ Litre Bottle	
Sparkling Wine & Champagne			
Villa Sandi Prosecco "Il Fresco" Brut, Treviso DOC	16	-	68
Tantalus Wedgewood Cuvee Blanc De Noir, Okanagan, BC	26		107
Domaine Rolet, Cremant du Jura Brut, Jura, France	26	-	107
Taittinger Brut Réserve, Champagne, France	40	-	168
Non- Alcoholic Sparkling Wine			
Glimmer, Blanc de Blanc, Penticton, BC	16		70
White Wine			
Schmitt Söhne 'Clean Slate' Riesling Mosel, Germany	15	42	60
Laughing Stock, Pinot Gris, Crafted in BC	16.5	45.5	66
Weingut Malat, 'Crazy Creatures' Grüner Veltliner, Kremstal, Austria	16.5	45.5	66
Clos du Soleil 'Fumé Blanc' Sauvignon Blanc, Similkameen Valley, BC	17	47.5	71
Tantalus Vineyards, Riesling, Crafted in BC	18	51	73
Quails' Gate Estate Winery, Chenin Blanc, Okanagan BC	18	51	73
Louis Latour, Chardonnay, Burgundy, France	19	54	78
Hubert Brochard 'Tradition' Sancerre Loire Valley, France	26.5	74	106
Domaine Courtalt- Michelet Chardonnay Chablis, France	26.5	74	106
Mission Hill Legacy Collection 'Perpetua' Chardonnay, Okanagan, BC	37	-	151 Coravin™
Heitz Cellars, Chardonnay, Napa Valley	47	-	189 Coravin™

WINE	6oz	½ Litre	Bottle
Rose Wine			
Mirabeau 'Pure', Côtes de Provence, France	20	57	82
La Stella 'Rosato', Carbenet Franc, Okanagan, BC	20	57	82
Red Wine			
Liberty School, Cabernet Sauvignon, Paso Robles, California	16.5	45.5	66
Lake Breeze Vineyards, Merlot, Naramata, BC	17	49	71
Gérard Bertrand 'Heritage An 560', Blend Côtes du Roussillon Tautavel, France	17	49	71
Maison Smith Montpetit, 'Reserve' Cabernet Franc, Similkameen Valley, BC	18	52	73
Terrazas de los Andes Reserva, Malbec, Mendoza, Argentina	19	53	77
Château Peyrouley, Bordeaux, France	20	54	78
Beronia Reserva, Rioja, Spain	20	54	78
San Felice, 'Il Grigio', Chianti Classico Riserva, Tuscany, Italy	22	60	86
Little Engine 'Silver', Pinot Noir, Okanagan Valley, BC	22	60	86
2021 Hester Creek 'The Judge', Blend, Oliver, BC	29	-	117 Coravin™
2019 Margaux du Château Margaux, <i>Coravin™</i>	62.5	-	250 Coravin™
Sake			
Okunomatsu Junmai Dai-Ginjo 'Navy Blue' Fukushima, Japan	24		96
Okunomatsu Junmai Dai-Ginjo 'Gold Omachi' Fukushima, Japan	35		140

DESSERT WINES

	Vintage	2oz	Bottle
Sweet Wine			
Burrowing Owl, 'Coruja', Port Style Wine, BC	-	12.5	98
Château D'Armajan des Ormes, Sauternes, France	2016	18.5	111
Sperling Riesling, Late Harvest Vidal, Okanagan Valley, BC	2018	23	135
Port			
Dow's Late Bottle Vintage	2016	9	85
Taylor Fladgate Late Bottle Vintage	2017	9	85
Taylor Fladgate 10 Year Tawny	-	14	125
Taylor Fladgate 20 Year Tawny	-	22	210
Taylor Fladgate 30 Year Tawny	-	30	375
Taylor Fladgate 40 Year Tawny	-	40	500



BEER

Draught	Glass	Pint
	12oz	20oz
Rewind Beer Co, Laser Light Lager	9	12
Parkside Brewery, Humans IPA	11	14
Parkside Brewery, Dusk Pale Ale	9	12
Slackwater Brewing, Idleback Amber Ale	11	14
Warsteiner, Pilsner, Germany	11	14
Guinness Irish Stout, Ireland	12	15

BOTTLE

Domestic | 9.5

Coors Light
Kokanee
Molson Canadian

Cider

Bricker Original Cider | 14
Bricker Earl Grey Dry Cider | 15.5

Imported | 10.5

Corona
Stella Artois
Heineken
Kronenbourg Blanc

Non-Alcoholic | 8

Heineken
Ginger Beer

Erdinger Weissbier 500 ml | 13

SPIRITS



SCOTCH | *one ounce pour*

Highland

Glenlivet 12 yr	14
Glenlivet 21 yr	41
Glenfiddich 12 yr	14
Glenfiddich 15 yr Solera Vat	19
Glenmorangie 14 yr Port Cask	20
Glenmorangie 10 yr	18
Cragganmore 12 yr	20
Dalwinnie 15 yr	23
Macallan 12 yr Double Cask	19
Glenmorangie Nectar D'Or	25
Oban 14 yr	27
Highland Park 18 yr	34.5
Dalmore 12 yr	15
Dalmore 15 yr	30
Dalmore 18 yr	80

Skye

Talisker 10 yr 25

Islay

Lagavulin 8 yr	17
Lagavulin 16 yr	27
Ardbeg 10 yr	19
Laphroaig	19

Jura

Mount Jura Superstition 15

Dalmore flight '45 years of Dalmore' (3 oz)

110

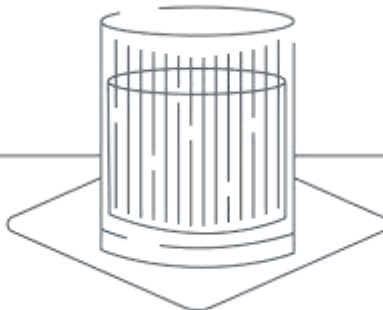

WHISKEY | *one ounce pour*

Blended Scotch

Johnnie Walker Red	11.5
Johnnie Walker Black	14.5
Johnnie Walker Blue	42

Canadian Whisky

Canadian Club	10.5
Crown Royal	11.5
Regent Road	11.5
Canadian Club 12 yr	12

Irish Whiskey

Jameson	12.5
Tullamore Dew	12.5
Bushmills Blackbush	14.5
Jameson	12.5
Tullamore Dew	12.5
Bushmills Blackbush	14.5

BC Whisky

Shelter Point 'Ripple Rock'	14
Shelter Point 'Cask' Strength Single Malt	17

Japanese Whiskey

Nikka From the Barrel	22
-----------------------	----

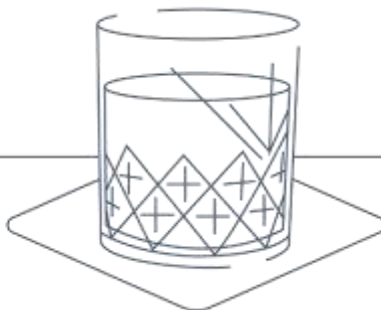

SPIRITS | *One ounce pour*

Vodka

Ketel One	12
Luksusowa	12
Stolichnaya	11.5
Belvedere	13.5
Grey Goose	13.5
Octavia	13.5
Belvedere B10	35

Gin

Tanqueray	12
Bombay East	12.5
Beefeater	12.5
Bombay Sapphire	12.5
Elephant London Dry	14.5
Hendrick's	14.5
The Botanist	14.5
Empress 1908 Indigo	14.5
Empress 1908 Elderflower	14.5
Sheringham Seaside	14.5
Monkey 47	21
Citadelle	14.5

Rum

Bacardi White	11
Bacardi Black	11
Captain Morgan	12
Gosling Black Seal	12.5
Bacardi 8	12.5
Flor De Cana 18 YR	16
Diplomatico Exclusiva	17

Cachaça

51 Cachaça	11.5
------------	------

Eau De Vie & Grappa

Bottega 'Alexander' Grappa	12.5
Tignanello Grappa	15.5
Grappa di Sassicaia 2015	29

SPIRITS | *One ounce pour*

Cognac

Courvoisier VS	14.5
Courvoisier VSOP	19
Courvoisier XO	36
Hennessy VS	12.5
Hennessy VSOP	18
Hennessy XO	45
Remy Martin VSOP	18
Remy Martin XO	42.5
Remy Martin Louis XIII	281

Tequila

El Tequileno Reposado	13.5
Maestro Dobel Cristalino	16
Patron Silver	19.5
Don Julio Blanco	19.5
Don Julio Reposado	21
Casamigos Blanco	25
Casamigos Reposado	26
El Tequileno Anejo	28
Clase Azul Plata	32
Don Julio 1942	40
Clase Azul Reposado	40
El Tequileno Extra Anejo	90

Liqueurs & Digestifs

Luxardo Limoncello	9.5
Frangelico	10.5
Disaronno Amaretto	10.5
Kahlua	10.5
Chambord Royal	12.5
Tia Maria	10.5
Jägermeister	12.5
Fernet Branca	12.5
Grand Marnier Cordon Rouge	12.5
Grand Marnier Cuvée Du Centenaire	20

Brandy

Metaxa Seven Star	12.5
St. Rémy VSOP	12.5

Armagnac

Chateau De Laubade 2006	22
-------------------------	----

Mezcal

400 Conjos Mezcal	13.5
Clase Azul Mezcal	48

SPECIALITY COFFEE & TEA | *one ounce pour*

Irish | 15
Jameson Whiskey and Coffee

Blueberry Tea | 16
Amaretto, Grand Marnier and
Orange Pekoe Tea

After 8 | 15
Peppermint Schnapps and Hot
Chocolate

Mellow Monk | 15
Bailey's Irish Cream, Frangelico

The Greek | 15
Metaxa, Tia Maria and Coffee

Northern Lights | 16
Absolut Vanilla, Bailey's Irish Cream
and Hot Chocolate

TEALEAVES Tea | 6

Teas For Change
Himalayan Mountain Tea
Himalayan Meadow Chamomile

Herbal Infusions
Harmony
Peppermint Leaves
Lemon Verbena

Traditional Black Tea Blends
English Breakfast
Decaf English Breakfast
Lavender Earl Grey
Classic Orange Pekoe
Shanghai Rose

Scented Green Teas
Organic Floral Jasmine Green Tea
Imperial Dragonwell

Coffee

Freshly Brewed Artisan Italian Coffee
Thermos | 7

Espresso | 7.5

Caffè Mocha | 7.5

Caffè Latte | 7.5

Cappuccino | 7.5

Flat White | 7.5

Add extra shot to your coffee | +1

Hot Chocolate | 7.5

FOOD

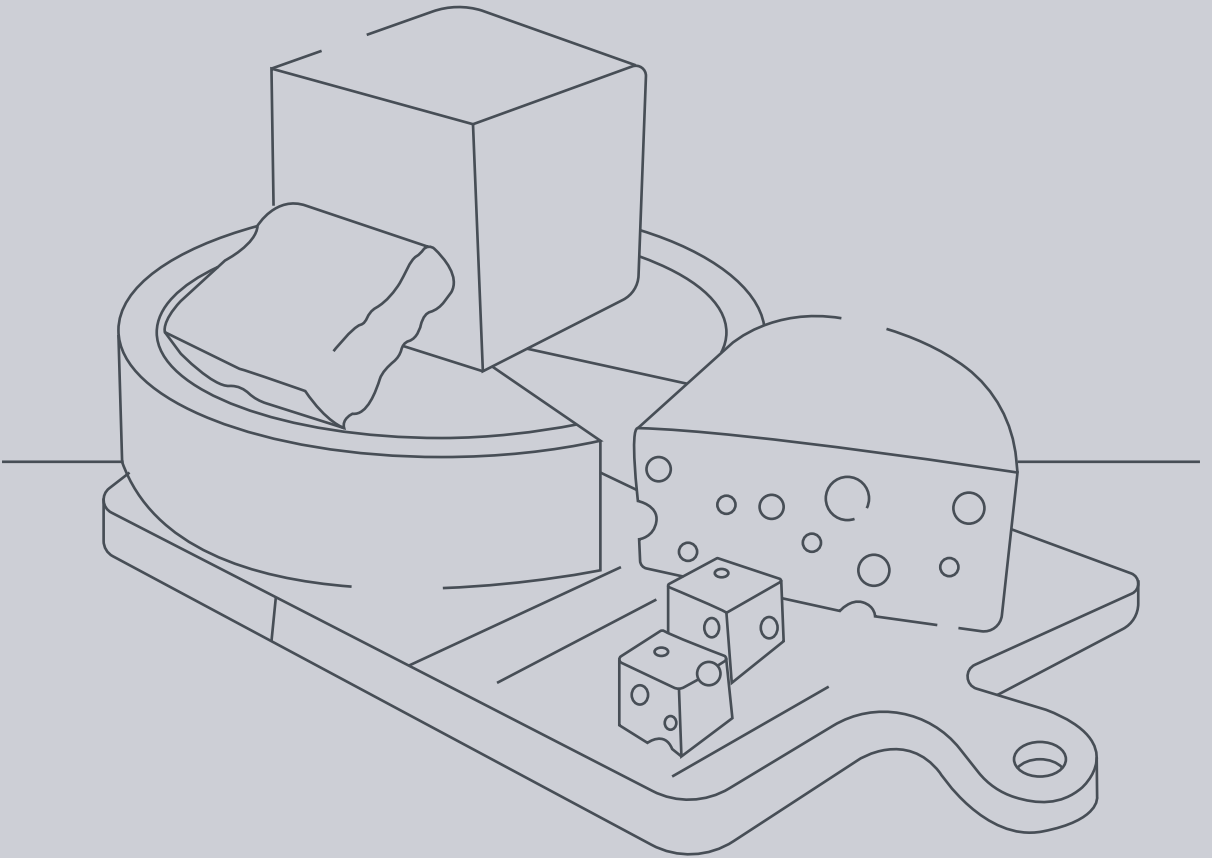

FOR THE TABLE

Bacchus Two Tier Seafood Tower | 225

Available daily until 2:30pm – 10pm

Poached Lobster, Albacore Tuna, Chilled Prawns & Cocktail Sauce, Poached Mussels Tartare, Dungeness Crab Roll, Marinated Baby Shrimp in Marie Rose Sauce, Oysters, Candied Salmon, Scallop Ceviche

Seafood Platter | 120

Albacore Tuna, Chilled Prawns & Cocktail Sauce, Dungeness Crab Roll, West Coast Oysters

Local West Coast Oysters (GF)

6 for 26 | 12 for 50

Classic Mignonette & Cocktail Sauce

~~Artisanal Caviar \$15~~

Kaviari® Caviar

Baeri | 150 Kristal | 175

20g of your selection, traditional accompaniments:
Blinis, Potato Rosti, Chives, Shallots, Egg White, Egg Yolk,
Crème fraîche

*The consumption of raw oysters poses an increased risk of foodborne illness.
A cooking step is needed to eliminate potential bacteria or viral contamination.*

(V) Vegetarian (VE) Vegan (GF) Gluten Free

Charcuterie Board | 45

A Selection of Cured Meats and Fine Cheese, House Made Preserves, Raincoast Crackers, Rye Bread Crisps & Candied Pecans

Fine Farmhouse Canadian Cheese

Select 3oz for 28 | 5oz for 45

Seasonal Fruit Preserves, Candied Pecans, Raincoast Crackers & Rye Bread Crisps

Comox Camembert, Courtney, BC

Creamy and Rich with Notes of Mushroom with a Tender Bloomy Rind

5 Brothers, Woodstock, ON

Washed Rind, Cedar Plank Aged, Creamy with a Slightly Sweet Finish

Bleu Bénédictin, Saint-Benoît-du-Lac, QC

Semi Soft, Natural Rind, Savoury with an Earthy Finish

Le Cendrillon, St. Raymond, QC

Ash Covered, Bloomy Rind Goat Cheese, Tangy with a Mild Peppery Finish

Tete Dure, Noyan, QC

Semi Firm Washed Rind, Mildly Lactic, Fruity Aroma with a Buttery Finish

SMALL PLATES

Truffle Pommes Frites (V) Grana Padano, Truffle & Parmesan Abli, Chives	14
Mini Bacchus Burgers Stout Braised Onions, Cheddar, Mustard, Sesame Bun	18
Asparagus Ricotta Ravioli (V) Butter Emulsion, Semi-Dried Tomatos, Domenica Fiore Olive Oil, Parmesan	20 (4pcs) 32 (7pcs)
<i>Add Pan-Seared Scallops (3pcs) +18</i> <i>Add Sautéed Prawns (3 pcs) +16</i>	
Baja Fish Tacos Battered Lingcod, Chipotle Salsa, Shaved Cabbage, Pico de Gallo, Flour Tortilla with Lime Wedges <i>Add Pommes Frites \$8</i>	24
Oven Roasted Tomato Bisque (V) (GF) Mascarpone, Basil <i>+ Mini Grilled Cheese Sandwich 6 + Scallop 6</i>	17
Prawn Cocktail (GF) Five Poached Prawns, Cocktail Sauce, Marie Rose Sauce, Horseradish & Lemon Wedge	32
Wild Garlic Pea Arancini (V) Aioli, Pecorino	16 (3pcs)
Albacore Tuna Teriyaki (DF) Avocado, Mango, Bell Pepper, Yuzu, Crispy Wonton	26
Pâté de Campagne Cornichons, Pistachio, Dijon Mustard, Baguette	24

BACCHUS FAVOURITES

Hand Peeled Shrimp or Turkey Clubhouse Toasted Multigrain, Double-Smoked Bacon, Aïoli, Butter Lettuce, Tomato, Pommes Frites <i>Substitute mini cobb salad +5</i>	26
Fried Buttermilk Chicken Vienna Style (GF)(DF) Potato Cucumber Salad, Lemon	22
The Bacchus Burger Alberta Beef, Double-Smoked Bacon, Aged Cheddar, Lettuce, Tomato, Onion, Pickle, Bacchus Sauce, House-Made Sesame Bun, Pommes Frites <i>Substitute mini cobb salad +5</i>	28
Crispy Fried Squid Preserved Lemon Aioli, Parsley, Lemon	20
Lounge Meatballs Slow Braised Beef & Pork Meatballs, Rich Tomato Sauce, Pecorino Cheese	20
Avocado & Shrimp Salad (GF) Marie Rose Sauce, Dill Aïoli, Microgreens	23 SM 38 LG
The Bacchus Cobb Salad (GF) Turkey, Crispy Prosciutto, Blue Cheese, Avocado, Egg, Tomatoes, Creamy Danish Blue Cheese Dressing	25
Chopped Salad (V) (GF) Feta, Tomato, Cucumber, Golden Beets, Artichoke, Shaved Fennel, Watermelon, Toasted Seeds, English Mustard Dressing <i>Add Grilled Chicken Breast +20</i> <i>Add Pan-Seared Salmon +22</i>	25

FRESH FROM OUR PIZZA OVEN

Margherita	23
Tomato, Fresh Basil, Buffalo Mozzarella	
Funghi (V)	25
Seasonal Mushrooms, Buffalo Mozzarella, Basil, Goat Cheese	
Pepperoni	25
Pepperoni, Parmigiano-Reggiano, Buffalo Mozzarella	
Rustica	25
Wine Chorizo Sausage, Buffalo Mozzarella	

DESSERT

Strawberry Savarin	16
Rhubarb Compote, Fresh Strawberry Salad, Vanilla Ice Cream	
Bailey Tiramisu	16
Vanilla Mascarpone Cream, Baileys Caramel, Chocolate, Fresh Raspberries	
Tropical Fruit Tart	16
Mango Passionfruit Cream, Toasted Coconut Crumble, Roasted Pineapple Compote, Mango Sorbet	
Affogato	14
Ice Cream, Freshly Brewed Espresso	

OFFICIAL PARTNERS 2026

