

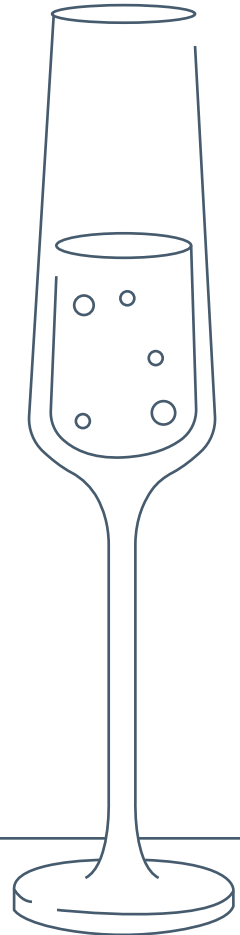

WEDGEWOOD
HOTEL & SPA

BACCHUS
LOUNGE &
COCKTAIL
MENU



COCKTAILS

WINE

SPIRITS

FOOD

COCKTAILS

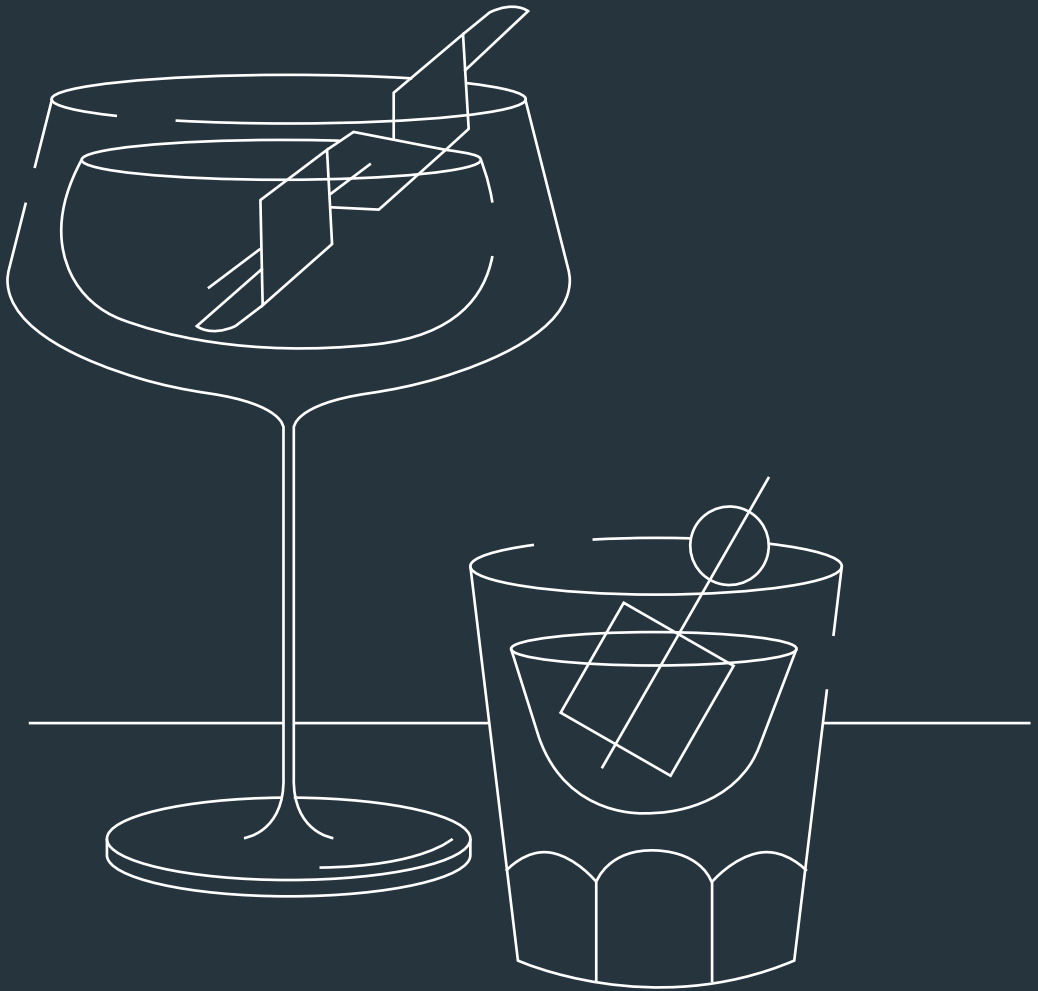

Summer Cocktails

Daybreak | 28

Cool cucumber and lime, lifted by soft sweetness, finishing fresh and delicately airy.

1.5 oz Hendrick's Gin, 0.5 oz Elderflower Liqueur, Cucumber Water, Basil-Mint Syrup, Fresh Lime Juice

Island's Light | 22

All the familiar flavours of a Piña Colada, reimagined with clarity and smoothness.

1.5 oz Dark Rum, 0.5 oz Spiced Rum, Cream of Coconut, Pineapple Juice, Fresh Lime Juice

The Pink Hour | 24

Juicy watermelon and bright citrus, lifted by subtle sweetness, with a clean and refreshing finish.

1.5 oz Blanco Tequila, 0.5 oz Campari, Watermelon Syrup, Fresh Lime Juice, Egg Whites

Sundown | 22

Ripe strawberry and banana, layered with gentle sweetness, balanced by citrus, and a mellow, rounded finish.

1.25 oz Dark Rum, 0.5 oz Banana Liqueur, 0.25 oz Vanilla Liqueur, Fresh Lemon Juice, Coconut Syrup, Strawberry

Evening Bloom | 28

A vibrant balance of dark berries and citrus, with soft spice and a light sparkle.

1.5 oz Reposado Tequila, 0.5 oz Blackcurrant Liqueur, Fresh Lime Juice, Thyme Syrup, 0.5 oz Lambrusco

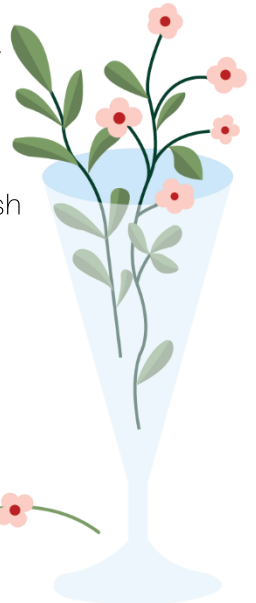

Mocktails

SGT Pepper | 14

Pineapple, Lemon, Simple Syrup, Tonic, Cucumber, Pepper

Ginger Lotus | 12

Ginger Beer, Orange Juice, Lemon

No-groni | 14

Bitter, sweet, herbal complexity with citrus notes

NOA Non-Alcoholic Vermouth, Italian Aperitif, and Gin, Muddled Orange Peel

Espresso Mocktini | 15

Coffee-forward, smooth, gently sweet

NOA Non-Alcoholic Coffee Liqueur, NOA Amaretto, Fresh Espresso, Simple Syrup

Hai Tea Mojito or Hibiscus | 11

355ml Can

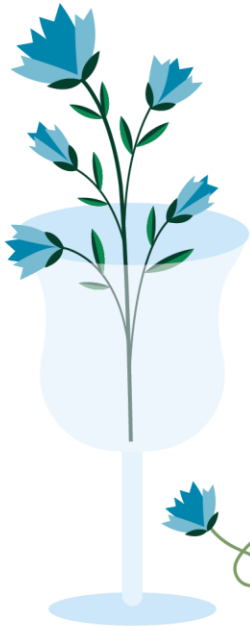

2 oz CLASSICS

Moscow Mule | 19

Ketel One Vodka, Lime Juice, Ginger Beer, Lime

Clover Club | 21

Tanqueray Gin, Chambord, Lemon Juice, Sugar, Egg White

Dark N' Stormy | 19

Goslings Rum, Lime Juice, Ginger Beer, Angostura Bitters, Mint

Sazerac | 20

Canadian Club, Angostura Bitter, Peychaud's, Sugar

Corpse Reviver No. 2 | 19

Tanqueray Gin, Lillet, Cointreau, Lemon Juice, Pernod

Hemingway Daquiri | 18

Bacardi White Rum, Maraschino liqueur, Lime Juice, Grapefruit Juice, Sugar

2oz MODERN CLASSICS

Revolver | 21

Bourbon, Tia Maria, Orange Bitters, Orange Peel

Old Cuban | 20

8 Year Bacardi, Lime Juice, Sugar, Angostura Bitters, Sparkling Wine

Dalmatian | 20

Luksusowa Vodka, Sugar, Grapefruit Juice, Cracked Black Pepper

Honey Bee | 26

Casamigos Reposado, St Germain Honey, Prosecco, Honey Comb

Gin Basil Smash | 18

Tanqueray Gin, Lemon Juice, Sugar, Basil

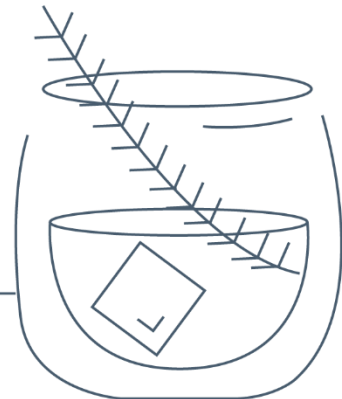

WINE



WINE

6oz ½ Litre Bottle
(750ml)

Sparkling Wine & Champagne

Lambrusco di Sorbara, Cantina de Carpe 'Emma' <i>Emilia-Romagna, DOC, Italy</i>	16	68
Prosecco , Villa Sandi 'Il Fresco', Brut, <i>Treviso DOC, Italy</i>	16	68
Blanc de Noir , Tantalus 'Wedgewood Cuveé' <i>East Kelowna Slopes, BC</i>	26	107
Cremant du Jura Brut Domaine Rolet, <i>Jura, France</i>	26	107
Champagne , Taittinger Brut Réserve, Champagne, <i>France</i>	40	168

Non- Alcoholic Sparkling Wine

Blanc de Blanc , Glimmer, <i>Penticton, BC</i>	16	70
---	----	----

White Wine

Riesling , Schmitt Söhne 'Clean Slate' <i>Mosel, Germany</i>	15	42	60
Pinot Gris , Laughing Stock, <i>Crafted in BC</i>	16.5	45.5	66
Grüner Veltliner , Weingut Malat, 'Crazy Creatures', <i>Kremstal, Austria</i>	16.5	45.5	66
Sauvignon Blanc , Clos du Soleil 'Fumé Blanc' <i>Similkameen Valley, BC</i>	17	47.5	71
Riesling , Tantalus Vineyards, <i>East Kelowna Slopes, Okanagan, BC</i>	18	51	73
Chenin Blanc , Quails' Gate Estate Winery, <i>Okanagan BC</i>	18	51	73
Chardonnay , Louis Latour, <i>Bourgogne, France</i>	19	54	78
Sauvignon Blanc , Hubert Brochard 'Tradition' Sancerre, <i>Loire Valley, France</i>	26.5	74	106
Chardonnay , Domaine Courtalt- Michelet <i>Chablis, France</i>	26.5	74	106
Chardonnay , Mission Hill Legacy Collection 'Perpetua' <i>Okanagan, BC</i>	37		151 <i>Coravin™</i>
Chardonnay , Heitz Cellars, <i>Napa Valley</i>	47		189 <i>Coravin™</i>

WINE

	6oz	½ Litre	Bottle (750ml)
Rose Wine			
Cabernet Franc , LaStella 'Rosato', <i>Okanagan, BC</i>	20	57	82
Grenache-Syrah-Cinsault , Mirabeau 'Pure', <i>Côtes de Provence, France</i>	20	57	82
Red Wine			
Cabernet Sauvignon , Liberty School <i>Paso Robles, California</i>	16.5	45.5	66
Merlot , Lake Breeze Vineyards, <i>Naramata, BC</i>	17	49	71
Grenache-Syrah , Gérard Bertrand <i>Côtes du Roussillon Tautavel, France</i>	17	49	71
Cabernet Franc , Maison Smith Montpetit 'Reserve', <i>Similkameen Valley, BC</i>	18	52	73
Malbec , Terrazas de los Andes, Reserva <i>Mendoza, Argentina</i>	19	53	77
Cabernet Blend , Château Peyrouley, <i>Bordeaux, France</i>	20	54	78
Tempranillo , Beronia Reserva, <i>Rioja, Spain</i>	20	54	78
Sangiovese , San Felice, 'Il Grigio' <i>Chianti Classico Riserva, Tuscany, Italy</i>	22	60	86
Pinot Noir , Little Engine 'Silver', <i>Okanagan, BC</i>	22	60	86
Cabernet Blend , Hester Creek, 'The Judge' 2021, <i>Oliver, BC</i>	29	-	117 <i>Coravin™</i>
Cabernet Blend , Margaux du Ch. Margaux 2019, <i>Bordeaux, France</i>	62.5	-	250 <i>Coravin™</i>
Sake			
Okunomatsu Junmai Dai-Ginjo 'Navy Blue' <i>Fukushima, Japan</i>	24		96
Tamanohikari Junmai Dai-Ginjo 'Gold Omachi' <i>Kyoto, Japan</i>	35		140

DESSERT WINES

	Vintage	2oz	Bottle (750ml)
Sweet Wine			
Burrowing Owl 'Coruja' , Port Style Wine <i>Oliver, BC</i>	2022	12.5	98
Tenute Falezza Recioto della Valpolicella DOCG <i>Veneto, Italy</i>	2020	13	99
Chateau D'Armajan des Ormes , Sauternes <i>Bordeaux, France</i>	2020	18.5	111
Chateau d'Yquem , 1er Cru Supérieur Sauternes, <i>Bordeaux, France</i>	2010		1200

Port

Dow's Late Bottle Vintage	2020	9	85
Taylor Fladgate Late Bottle Vintage	2020	9	85
Taylor Fladgate 10 Year Tawny	-	14	125
Taylor Fladgate 20 Year Tawny	-	22	210
Taylor Fladgate 30 Year Tawny	-	30	375
Taylor Fladgate 40 Year Tawny	-	40	500



BEER

Draught

	Glass	Pint
	12oz	20oz
Rewind Beer Co, Laser Light Lager	9	12
Parkside Brewery, Humans IPA	11	14
Parkside Brewery, Dusk Pale Ale	9	12
Slackwater Brewing, Idleback Amber Ale	11	14
Warsteiner, Pilsner, Germany	11	14
Guinness Irish Stout, Ireland	12	15

BOTTLE (375ml)

Domestic | 9.5

Coors Light
Kokanee
Molson Canadian

Imported | 10.5

Corona
Stella Artois
Heineken
Kronenbourg Blanc

Erdinger Weissbier 500 ml | 13

Cider

Bricker Original Cider | 14
Bricker Earl Grey Dry Cider | 15.5

Non-Alcoholic | 8

Heineken
Ginger Beer

SPIRITS



SCOTCH | *one ounce pour*

Highland

Glenlivet 12 yr	14
Glenlivet 21 yr	41
Glenfiddich 12 yr	14
Glenfiddich 15 yr Solera Vat	19
Glenmorangie 14 yr Port Cask	20
Glenmorangie 10 yr	18
Cragganmore 12 yr	20
Dalwhinnie 15 yr	23
Macallan 12 yr Double Cask	19
Glenmorangie Nectar D'Or	25
Oban 14 yr	27
Highland Park 18 yr	34.5
Dalmore 12 yr	15
Dalmore 15 yr	30
Dalmore 18 yr	80

Skye

Talisker 10 yr 25

Islay

Lagavulin 8 yr	17
Lagavulin 16 yr	27
Ardbeg 10 yr	19
Laphroaig	19

Jura

Mount Jura Superstition 15

Dalmore flight '45 years of Dalmore' (3 oz)

110

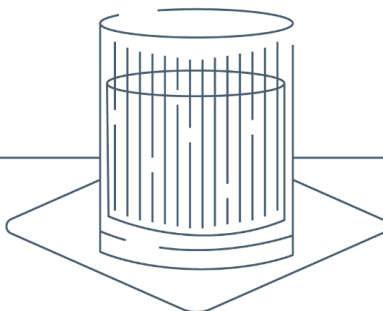

WHISKEY | *one ounce pour***Blended Scotch**

Johnnie Walker Red	11.5
Johnnie Walker Black	14.5
Johnnie Walker Blue	42

Canadian Whisky

Canadian Club	10.5
Crown Royal	11.5
Regent Road	11.5
Canadian Club 12 yr	12

Irish Whiskey

Jameson	12.5
Tullamore Dew	12.5
Bushmills Blackbush	14.5
Jameson	12.5
Tullamore Dew	12.5
Bushmills Blackbush	14.5

BC Whisky

Shelter Point 'Ripple Rock'	14
Shelter Point 'Oak' Strength Single Malt	17

Japanese Whiskey

Nikka From the Barrel	22
-----------------------	----

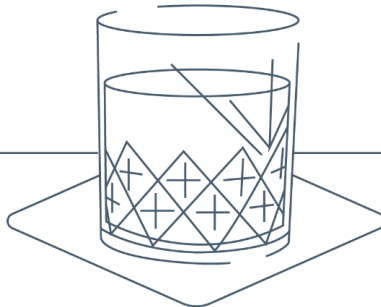

SPIRITS | *One ounce pour***Vodka**

Ketel One	12
Luksusowa	12
Stolichnaya	11.5
Belvedere	13.5
Grey Goose	13.5
Octavia	13.5
Belvedere B10	35

Rum

Bacardi White	11
Bacardi Black	11
Captain Morgan	12
Gosling Black Seal	12.5
Bacardi 8	12.5
Flor De Cana 18 YR	16
Diplomatico Exclusiva	17

Cachaça

51 Cachaça	11.5
------------	------

Gin

Tanqueray	12
Bombay East	12.5
Beefeater	12.5
Bombay Sapphire	12.5
Elephant London Dry	14.5
Hendrick's	14.5
The Botanist	14.5
Empress 1908 Indigo	14.5
Empress 1908 Elderflower	14.5
Sheringham Seaside	14.5
Monkey 47	21
Citadelle	14.5

Eau De Vie & Grappa

Bottega 'Alexander' Grappa	12.5
Tignanello Grappa	15.5
Grappa di Sassicaia 2015	29

SPIRITS | *One ounce pour***Cognac**

Courvoisier VS	14.5
Courvoisier VSOP	19
Courvoisier XO	36
Hennessy VS	12.5
Hennessy VSOP	18
Hennessy XO	45
Remy Martin VSOP	18
Remy Martin XO	42.5
Remy Martin Louis XIII	281

Liqueurs & Digestifs

Luxardo Limoncello	9.5
Frangelico	10.5
Disaronno Amaretto	10.5
Kahlua	10.5
Chambord Royal	12.5
Tia Maria	10.5
Jägermeister	12.5
Fernet Branca	12.5
Grand Marnier Cordon Rouge	12.5
Grand Marnier Cuvée Du Centenaire	20

Tequila

El Tequileno Reposado	13.5
Maestro Dobel Cristalino	16
Patron Silver	19.5
Don Julio Blanco	19.5
Don Julio Reposado	21
Casamigos Blanco	25
Casamigos Reposado	26
El Tequileno Anejo	28
Clase Azul Plata	32
Don Julio 1942	40
Clase Azul Reposado	40
El Tequileno Extra Anejo	90

Brandy

Metaxa Seven Star	12.5
St. Rémy VSOP	12.5

Armagnac

Chateau De Laubade 2006	22
-------------------------	----

Mezcal

400 Conijos Mezcal	13.5
Clase Azul Mezcal	48

SPECIALITY COFFEE & TEA | *one ounce pour*

Irish | 15

Jameson Whiskey and Coffee

Blueberry Tea | 16

Amaretto, Grand Marnier and Orange Pekoe Tea

After 8 | 15

Peppermint Schnapps and Hot Chocolate

Mellow Monk | 15

Bailey's Irish Cream, Frangelico

The Greek | 15

Metaxa, Tia Maria and Coffee

Northern Lights | 16

Absolut Vanilla, Bailey's Irish Cream and Hot Chocolate

TEALEAVES Tea | 6

Teas For Change

Himalayan Mountain Tea
Himalayan Meadow Chamomile

Herbal Infusions

Harmony
Peppermint Leaves
Lemon Verbena

Traditional Black Tea Blends

English Breakfast
Decaf English Breakfast
Lavender Earl Grey
Classic Orange Pekoe
Shanghai Rose

Scented Green Teas

Organic Floral Jasmine Green Tea
Imperial Dragonwell

Coffee

Freshly Brewed Artisan Italian Coffee
Thermos | 7

Espresso | 7.5

Caffè Mocha | 7.5

Caffè Latte | 7.5

Cappuccino | 7.5

Flat White | 7.5

Add extra shot to your coffee | +1

Hot Chocolate | 7.5

FOOD

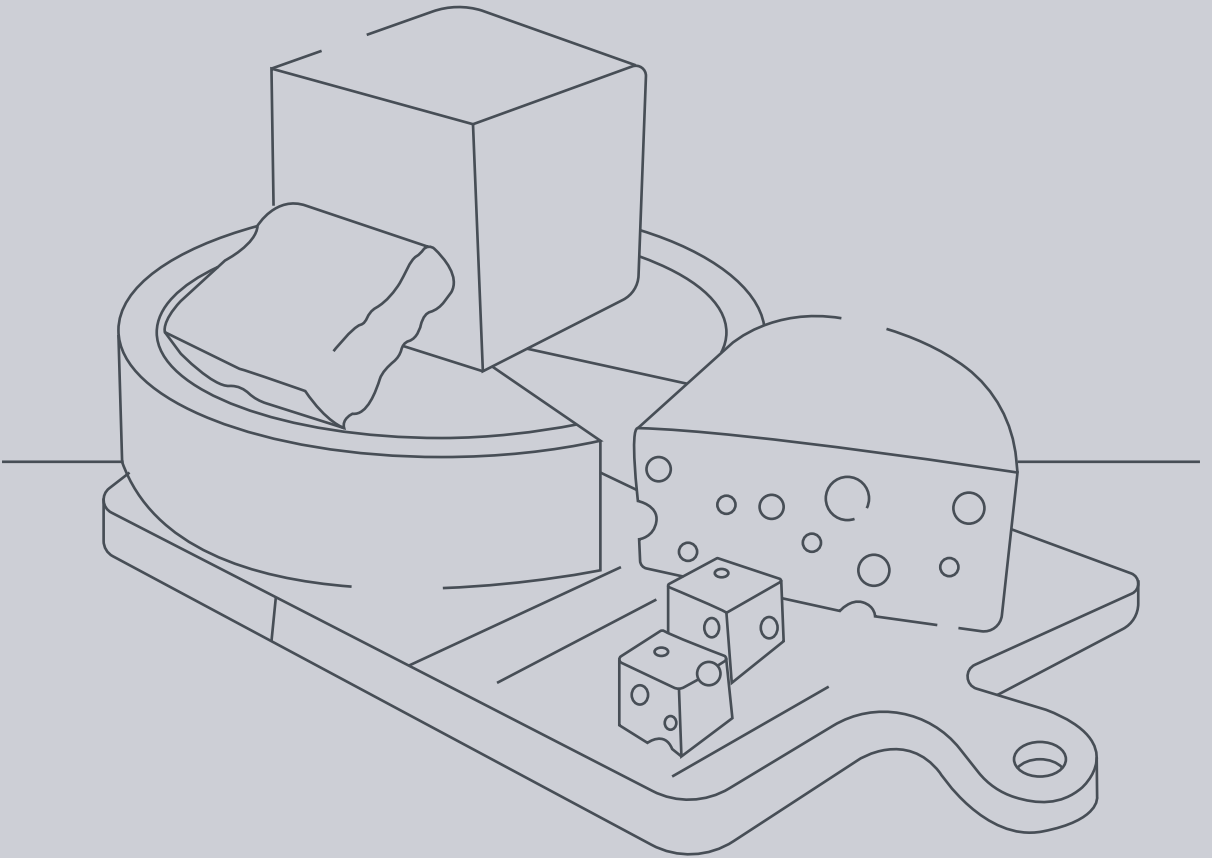

FOR THE TABLE

Bacchus Two Tier Seafood Tower | 225

Available daily until 2:30pm – 10pm

Poached Lobster, Albacore Tuna, Chilled Prawns & Cocktail Sauce, Poached Mussels Tartare, Dungeness Crab Roll, Marinated Baby Shrimp in Marie Rose Sauce, Oysters, Candied Salmon, Scallop Ceviche

Seafood Platter | 120

Albacore Tuna, Chilled Prawns & Cocktail Sauce, Dungeness Crab Roll, West Coast Oysters

Local West Coast Oysters (GF)

6 for 26 | 12 for 50

Classic Mignonette & Cocktail Sauce
Add 1oz. Octavia Vodka 135

Kaviari® Caviar

Baeri | 150 Kristal | 175

20g of your selection, traditional accompaniments:
Blinis, Potato Rosti, Chives, Shallots, Egg White, Egg Yolk,
Crème fraîche

The consumption of raw oysters poses an increased risk of foodborne illness. A cooking step is needed to eliminate potential bacteria or viral contamination.

(V) Vegetarian (VE) Vegan (GF) Gluten Free

Charcuterie Board | 45

A Selection of Cured Meats and Fine Cheese, House Made Preserves, Raincoast Crackers, Rye Bread Crisps & Candied Pecans

Fine Farmhouse Canadian Cheese

Select 3oz for 28 | 5oz for 45

Seasonal Fruit Preserves, Candied Pecans, Raincoast Crackers & Rye Bread Crisps

Comox Camembert, Courtney, BC

Creamy and Rich with Notes of Mushroom with a Tender Bloomy Rind

5 Brothers, Woodstock, ON

Washed Rind, Cedar Plank Aged, Creamy with a Slightly Sweet Finish

Bleu Bénédictin, Saint-Benoît-du-Lac, QC

Semi Soft, Natural Rind, Savoury with an Earthy Finish

Le Cendrillon, St. Raymond, QC

Ash Covered, Bloomy Rind Goat Cheese, Tangy with a Mild Peppery Finish

Tete Dure, Noyan, QC

Semi Firm Washed Rind, Mildly Lactic, Fruity Aroma with a Buttery Finish

SMALL PLATES

Truffle Pommes Frites (V)	14
Grana Padano, Truffle & Parmesan Abli, Chives	
Mini Bacchus Burgers	18
Stout Braised Onions, Cheddar, Mustard, Sesame Bun	
Asparagus Ricotta Ravioli (V)	20 (4pcs) 32 (7pcs)
Butter Emulsion, Semi-Dried Tomatos, Domenica Fiore Olive Oil, Parmesan	
<i>Add Pan-Seared Scallops (3pcs) +18</i>	
<i>Add Sautéed Prawns (3pcs) +16</i>	
Baja Fish Tacos	24
Battered Lingcod, Chipotle Salsa, Shaved Cabbage, Pico de Gallo, Flour Tortilla with Lime Wedges	
<i>Add Pommes Frites \$8</i>	
Oven Roasted Tomato Bisque (V) (GF)	17
Mascarpone, Basil	
<i>+ Mini Grilled Cheese Sandwich 6 + Scallop 6</i>	
Prawn Cocktail (GF)	32
Five Poached Prawns, Cocktail Sauce, Marie Rose Sauce, Horseradish & Lemon Wedge	
Wild Garlic Pea Arancini (V)	16 (3pcs)
Aioli, Pecorino	
Albacore Tuna Teriyaki (DF)	26
Avocado, Mango, Bell Pepper, Yuzu, Crispy Wonton	
Pâté de Campagne	24
Cornichons, Pistachio, Dijon Mustard, Baguette	

BACCHUS FAVOURITES

Hand Peeled Shrimp or Turkey Clubhouse	26
Toasted Multigrain, Double-Smoked Bacon, Aioli, Butter Lettuce, Tomato, Pommes Frites <i>Substitute mini cobb salad +5</i>	
Fried Buttermilk Chicken Vienna Style (GF)(DF)	22
Potato Cucumber Salad, Lemon	
The Bacchus Burger	28
Alberta Beef, Double-Smoked Bacon, Aged Cheddar, Lettuce, Tomato, Onion, Pickle, Bacchus Sauce, House-Made Sesame Bun, Pommes Frites <i>Substitute mini cobb salad +5</i>	
Crispy Fried Squid	20
Preserved Lemon Aioli, Parsley, Lemon	
Lounge Meatballs	20
Slow Braised Beef & Pork Meatballs, Rich Tomato Sauce, Pecorino Cheese	
Avocado & Shrimp Salad (GF)	23 SM 38 LG
Marie Rose Sauce, Dill Aioli, Microgreens	
The Bacchus Cobb Salad (GF)	25
Turkey, Crispy Prosciutto, Blue Cheese, Avocado, Egg, Tomatoes, Creamy Danish Blue Cheese Dressing	
Chopped Salad (V) (GF)	25
Feta, Tomato, Cucumber, Golden Beets, Artichoke, Shaved Fennel, Watermelon, Toasted Seeds, English Mustard Dressing <i>Add Grilled Chicken Breast +20</i> <i>Add Pan-Seared Salmon +22</i>	

FRESH FROM OUR PIZZA OVEN

Margherita	23
Tomato, Fresh Basil, Buffalo Mozzarella	
Funghi (V)	25
Seasonal Mushrooms, Buffalo Mozzarella, Basil, Goat Cheese	
Pepperoni	25
Pepperoni, Parmigiano-Reggiano, Buffalo Mozzarella	
Rustica	25
Wine Chorizo Sausage, Buffalo Mozzarella	

DESSERT

Strawberry Savarin	16
Rhubarb Compote, Fresh Strawberry Salad, Vanilla Ice Cream	
Bailey Tiramisu	16
Vanilla Mascarpone Cream, Baileys Caramel, Chocolate, Fresh Raspberries	
Tropical Fruit Tart	16
Mango Passionfruit Cream, Toasted Coconut Crumble, Roasted Pineapple Compote, Mango Sorbet	
Affogato	14
Ice Cream, Freshly Brewed Espresso	

OFFICIAL PARTNERS 2026

